

# charlie's

MACHINE & SUPPLY, INC



## FRESH CUT FOOD MACHINERY

2013 - 2014

[www.CharliesMachineandSupply.com](http://www.CharliesMachineandSupply.com)

**PROCESSING MACHINERY FOR ALL YOUR FRESH CUT FRUIT AND VEGETABLE PROCESSING NEEDS**



## **Complete Turn-Key Fresh Cut & Wash Lines to Small Cutting Tools**

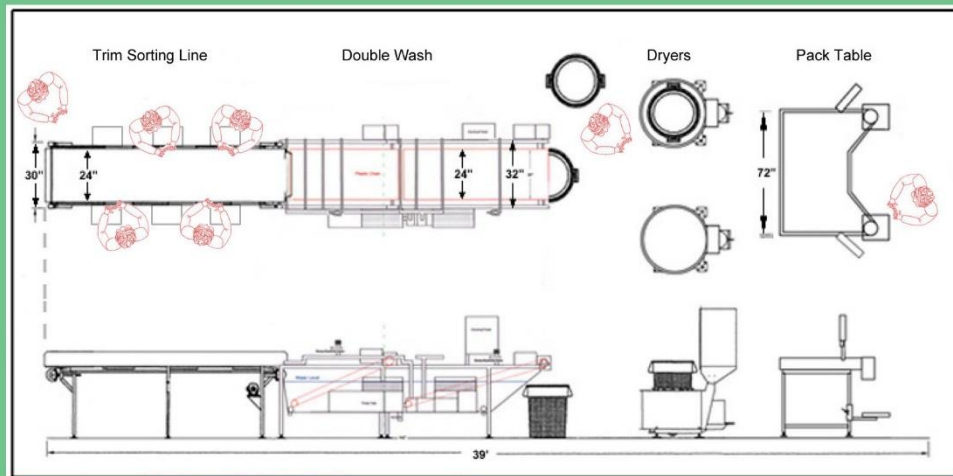

**Peeling, slicing, dicing, wedging, washing and chilling, drying, conveyors, chlorination systems weighing, packaging & sealing.**

**Custom Built - New - Used Equipment**

Prices subject to change.

**FOR ORDERS  
OR INFORMATION CALL**

**800-786-8455**

**For the East Coast CALL John  
770-287-0951**

**888-423-7086**

**For the West Coast CALL Charlie "T"  
303-682-2895**

**800-422-0694**

**For New England States CALL Steven  
401-396-9062**

**1067 S. Hover Street, E-181  
Longmont, CO 80503**

**303-443-9595**

**Fax: 866-291-2431**

**Email:**

**info@charliesmachineandsupply.com**

**Check out our Website:**

**FOR MORE EQUIPMENT & VIDEO DEMOS**

**www.charliesmachineandsupply.com**



**Charlie T**



**Steven**



**John**

**Charlie's Machine & Supply Inc. (CMS)** was founded in 1995 and is a nationwide leader in the distribution and manufacture of **fresh cut food** processing equipment.

Our goal at **CMS** is to understand your specialized processing applications. We are there every step of the way to insure that your needs are met by the **quality equipment we produce**, by our **labor saving designs** and by our **food safety technology**.

**Table of Contents**

**Peel, Wedge & Chunk. . . . . 2-3**  
 Carrot / Cucumber Peeler  
 Butternut Squash De-Seeder  
 Lettuce Chopper/Fruit Chunker  
 Deluxe Tomato Slicer  
 Knives

**Cut, Corer, Slice and Wedge. . . . . 4-5**  
 Block Cutter  
 Pepper Corer  
 Belt Cutter/Slicer  
 Belt Cutter/Slicer-Table Top  
 Air-Driven Dual Stick Cutter

**Apples & Pineapples . . . . . 6-9**  
 Apple Wedger 101  
 Multi-Use Hand Wedger  
 Apple Dual Air Wedger  
 Apple Peeler/Wedger/Corer  
 Pineapple Peeler/Corer  
 Pineapple Tuber/Corer/Peeler - Table Top  
 Pineapple Top & Tailer  
 Pineapple Slicer  
 Pneumatic Pineapple Corer/Peeler

**Slice, Dice & Wedge & Cut. . . . . 10-13**  
 Industrial Food Processors & Blades  
 Multi-Use Hand Cutters & Blades

**Potatos, Broccoli & Onions. . . . . 14-17**  
 Abrasive Roll Potato Peeler  
 60 lb. Abrasive Batch Peeler  
 20 lb. Abrasive Batch Peeler  
 air-driven Broccoli Floretter, Stand & Conveyor  
 Onion Carousel Slicer - Dual & Single Blade  
 Onion Slicer  
 Onion Top & Tail - Manual  
 Onion Peeler  
 Onion Top & Tail Processor

**Shakers and Cutters. . . . . 18**  
 Shaker Conveyor  
 Increment Cutter

**Wash & Chill. . . . . 19-21**  
 Vegetable & Fruit Wash  
 Single Washer  
 Spray & Wash Conveyor  
 Double Wash  
 Jr. Melon & Fruit Washer  
 Barrel Washer  
 Soak Tank

**Dryers. . . . . 22**  
 Continuous Feed Air Knife Drying Conveyor  
 Industrial Food Dryer  
 Veg Dryer

**Pack Tables. . . . . 23**  
 Pack Table w/ Digital Scales  
 Rotary Pack Table  
 Brick Stick Pack

**Chlorination, Detectors & Sealers. . . . . 24-25**  
 Klorman Chlorine Dispenser  
 Metal Detector  
 Horizontal Band Sealer with Conveyor  
 Vacuum Pack Sealer

**90% of the equipment shown in this catalog is  
manufactured in the USA.**

## Carrot/Cucumber Peeler

Is a complete carrot peeler system that reduces peeling time by up to **85%** on most carrots.

**Features:**

- Peels 30 lbs. of carrots in less than 10 minutes
- Simple to operate
- Excellent quality, dependable

**Complete  
w/Stainless Steel Clamping Stand  
Price \$450.00**



**NEW  
Stainless Steel  
Counter Stand  
with Clamp**

**COMPLETE WITH STAINLESS STEEL WALL BRACKET**

Model No.	Description	Ship Wt (lbs.)	Price
601564	Standard Carrot	3	\$ 350.00
601565	Large Carrot	3	\$ 350.00

**COMPLETE BLADE/HEAD ASSEMBLY**

Model No.	Description	Ship Wt (lbs.)	Price
653635	Standard Carrot	3	\$ 260.00
653659	Large Carrot	3	\$ 260.00

**REPLACEMENT KNIFE SETS**

Model No.	Description	Ship Wt (lbs.)	Price
653636	Standard Carrot	3	\$ 150.00
653637	Large Carrot	3	\$ 150.00

**NEW  
Stainless Steel  
Counter Stand**



**Complete  
w/Stainless Steel Stand  
Price \$420.00**



**ACCESSORIES / PARTS**

Model No.	Description	Price
653640-SS-CLAMP	Counter Stand - SS w/Clamp	\$ 195.00
653640-SS	Counter Stand - Stainless Steel	\$ 170.00
653641	Swing Arms - (Set of 6)	\$ 78.50
653642	Springs - (Set of 6)	\$ 35.00
653639-SS	Wall Bracket - Stainless Steel	\$ 95.00



## BUTTERNUT SQUASH DE-SEEDER

Make short work of "seeding" squash with this de-seeder. It's "U" shape design makes it easy to remove the seed cluster. Cut squash in half and with one swift scooping motion this squash deseeder has made a time consuming job efficient. **De-seeder available in 3 1/2"**

**Features:**

- Stainless Steel blade & handle
- Hand-crafted in the USA
- 6" Handle - Total Length 11" (3 1/2")

**Price \$ 75.00**

## Lettuce Chopper/Fruit Chunker

In one swift motion, the Lettuce Chopper/Fruit Chunker cuts or slices whole heads of lettuce into uniform pieces and handles melons the same way. **Up to 50 heads in 5 minutes without bruising or waste.** Frame is stainless steel. Choose between 1" squares or 1" slices. **Includes one upper and lower blade.** Other chunk sizes: (3/4" x 3/4", 1" x 2", 1-1/2" x 1-1/2", 2" x 2")

**Price \$ 895.00**

SPECIFICATIONS		
Model No.	Dimensions H x W x D	Ship Wt. (lbs.)
SKK2	27" x 17" x 17"	26

REPLACEMENT BLADE		
Model No.	Size	Price
25506	Upper	\$ 267.00
25507	Lower	\$ 267.00

**HEAVY DUTY!**  
**Perfect for Fruit Chunking**



## Deluxe Tomato Slicer

Cuts tomatoes into perfect slices keeping their original shape. Made of stainless steel and aluminum - unique micro tooth blades provide precision cuts on even soft tomatoes. Simply place tomatoes on the cradle and pull the lever. Replacement blades available. Can slice up to 20 tomatoes per minute. **1/4" - 11 slices.**

*Slices stay together for easy loading into trays*



**Price \$ 595.00**

### Features:

- Stainless steel "Micro-Saw" blades
- Easy to operate & clean
- Replacement blades available
- Non-skid food pads prevent movement
- Safety design avoids easy blade contact

SPECIFICATIONS		
Model No.	Dimensions H x W x D	Ship Wt. (lbs.)
601443	5 11/16" x 16 13/16" x 9 7/16"	9

## KNIVES

Here is a sample of our everyday processing knife line. Ask what else we have available and what we can create for you.

### Features:

- Stainless Steel Blades
- Plastic Handles
- Hand-crafted in the USA
- Top of the line quality



**Paring Knife**

**Items 130S - \$ 3.99ea**

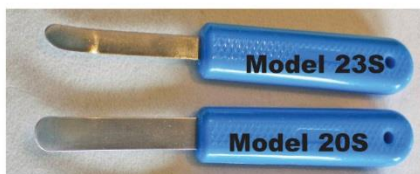

**Potato Knives - Item 20S - 1 1/2" x 2 1/2"**  
**Potato Knives - Item 23S - 1 3/8" x 2 1/2"**  
**\$ 4.50 ea**

**Pitting Spoons for Fruit - \$7.50 ea**  
**#2 - 2PTS Pitting Spoon - Pt Tip**  
**#7 - 7PTS Pitting Spoon - Long**  
**#3 - 3PTS Pitting Spoon - Round Tip**



**Trim Knives - \$ 3.95 ea**

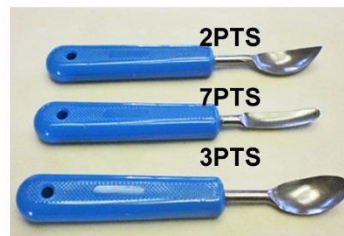

**CALL 800-786-8455 or E-mail [info@charliesmachineandsupply.com](mailto:info@charliesmachineandsupply.com)**

## Block Cutter

This manual increment cutter is lightweight and perfect for those small jobs that require precision length cuts every time. Easy to clean and store. Segmenting celery, carrots, squash and other long root and leafy **vegetables into uniform lengths with one swift pull-down.** Our standard size is 4" or can be custom made to your required length. Replacement blades available.

4" Block Cutter **Price \$ 795.00**

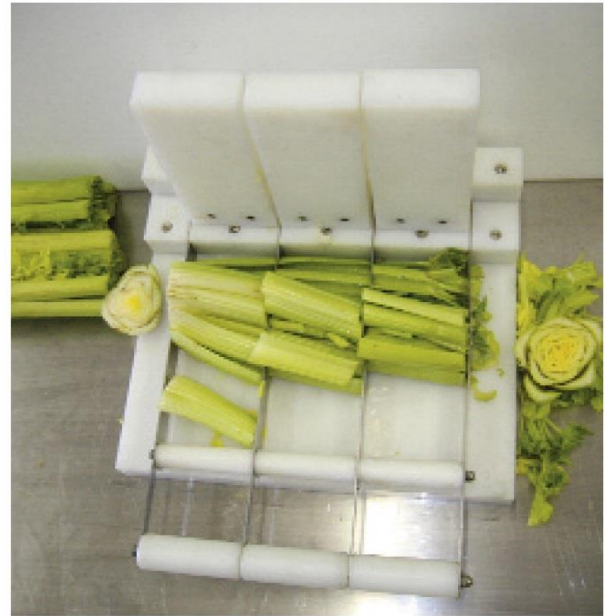

SPECIFICATIONS		
Model No.	Dimensions H x W x D	Ship Wt. (lbs.)
GER-BC	4 1/2" x 16" x 18"	10

2", 3", 3-1/2", 4", 5" and other sizes available.

## Pepper Corer

Manual pepper corer is an easy and simple way to CORE and SEED peppers. Place Pepper Corer over a standard size brute container; push down and twist; core and seeds waste drop through the corer tube into brute. Available with two (2) or three (3) Corer Blades. The stainless steel core cylinder measures 2"D. Custom sizing is available.

### Features:

- Stainless steel Coring blades
- Mounts on top of Brute container
- Two Blades for Faster Cutting
- 2" Diameter Cut or Custom Size
- Made in the USA

**Price - 2-Hole \$ 475.00**

SPECIFICATIONS	
Model No.	Ship Wt. (lbs.)
PCOR2	12



## Large Vegetable Belt Cutter/Slicer

This Celery, Green Onion, Leek, Scallion and Pepper Cutter/Slicer makes difficult to cut jobs a whole lot easier. Simply feed your celery, chard, green onion, cilantro or pepper onto the belt feeder and let the machine do the rest. Length of cut is easy to adjust. 1-60mm (1/16" to 2 3/8") adjustable slices.

### Features:

- Stainless Steel Construction
- Belts remove for easy cleaning
- Variable speed belt
- Belt width 5"



Celery Cut

**CALL FOR QUOTE**



SPECIFICATIONS		
Model No.	Power Requirements Electrical & Motor	Dimensions H x W x D
LG-BLT-SLR	230v x 1 phase	48" x 23.5" x 36.25"



### Table Top

## Small Vegetable Belt Cutter/Slicer

Same as our Large Belt Cutter/Slicer above - except this Table Top model is smaller and perfect for the small processor cutting green onions, leeks, scallions and chili peppers. Simply feed your chard, green onion, cilantro or chili pepper onto the belt feeder and let the machine do the rest. Length of cut is easy to adjust. 1mm to 30mm (1/16" to 1 3/16") adjustable slices.

**CALL FOR QUOTE**



SPECIFICATIONS		
Model No.	Power Requirements Electrical & Motor	Dimensions H x W x D
SM-BLT-SLR	120v x 1phase	20" x 14" x 21"

## Air-Driven Dual Stick Cutter

Uses the same blades as our Manual Hand Cutter (pg. 11), except the air-driven cutter improves product placement for specific cuts at higher 'air-driven' speeds. To operate, open the Lexan door and place product in the V-shaped trough. When the door is closed, air automatically pushes the product through blades for precise cuts. Stand not included. **Includes blade and pusher set.**

**CALL FOR QUOTE**

SPECIFICATIONS			
Model No.	Air Requirements	Dimensions H x W x D	Ship Wt. (lbs.)
AD-DSC	30 cycles 100 p.s.i. 16 c.f.m.	23" x 12 1/2" x 20"	60



## Apple Wedger 101

This manual pull-down system - with its "Rugged Industrial" Design - is perfect for wedging and coring. Ideal for APPLES, ORANGE, POTATOES. An optional Divider Pan is available to separate wedges from the core. Can be modified to cut Sticks, Slices or Wedge only or Core only. Replacement blades available. Model No. R-AW

**Features:**

- Up to 15 pieces per minute
- Wedges - , 8, 12, 14, 16
- Cores - 20 mm, 25 mm  
30mm or 35mm Core
- Hand-crafted in the USA
- Stainless Steel
- Double Stack Blade



**Price \$ 1,895.00**  
**APPLE WEDGE & CORE or WEDGE ONLY**



**Optional Wedge & Core Divider Pan \$475**



**DOUBLE STACK BLADE**

## Apple Wedger & Corer Workstation

**Price \$2,850**



## Multi-Use Hand Wedger - SEE PAGE 12

Perfect for wedging apples and various other fruits. Available in 4, 6 and 8 Segment Wedger blades. Does not remove the core. This durable and low-maintenance design is available for the countertop or wall mounting. See Page 12-13 for more information and blades available. **Includes blade head & pusher.**

**Features:**

- Lightweight
- Easy cleaning
- Safe and easy to operate
- Hand pull down plunger

**Price \$ 399.00**





## Apple Dual Air Wedger

This stainless steel air-driven machine is the safest and easiest way to cut wedges and core at the same time. It wedges apples as fast as you can load 2 apples at a time, up to about 30 per minute. Place the apples on the 12 or 16 Wedge —Double Stacked blades & push the two safety buttons simultaneously to engage the pusher. The pusher blocks, pushes the apples through the blades giving you perfectly cored and wedged apples every time. Replacement Blades Available. Built-in Divider Pan.

SPECIFICATIONS			
Model No.	Air Requirements	Dimensions H x W x D	Ship Wt. (lbs.)
R-ADAW	80 p.s.i. 12 cfm	42" x 22" x 16"	60



Apple Treatment System

CALL FOR QUOTE

Apple Dual Air Wedger



The Apple Dual Air Wedger can be converted to a complete apple line including: coneying, washing, treatment, air knife and packaging.

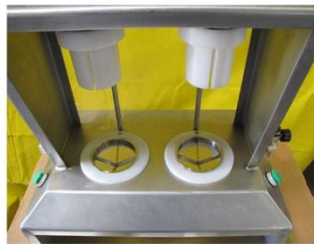

Dual Air 4 Wedge for Onions

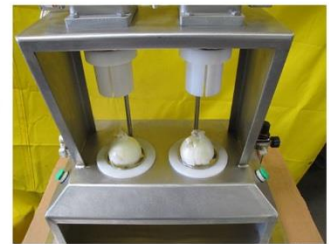

## Apple Peeler Wedger Corer

The Apple Peeler Wedger Corer (APWC) is a combination of three devices all in one compact rugged design. The Hand Operated Parer (Peeler) & Corer is mounted on a sturdy 30" x 30" Stainless Steel work table with legs on casters. Once peeled and cored, a Seed Cellar helps to trim out any unwanted core pieces left in the apple. The last step on the machine is a Hand Operated Wedger. Choose between a 10, 12 or 14 wedging blade. **Includes 3/4" Coring Knife and 5/5" paring fork.**  
Model NO. APWC

### Features:

- Industrial Rugged
- Can Peel, Core and Wedge 12 to 18 apples per minute.
- Manually Operated
- Made in the USA

CALL FOR QUOTE

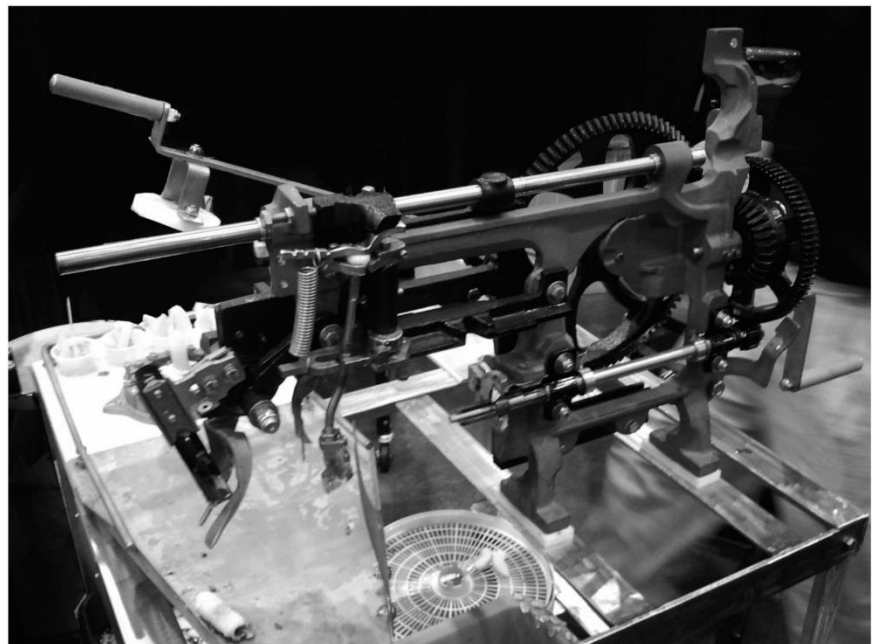

CALL 800-786-8455 or E-mail [info@charliesmachineandsupply.com](mailto:info@charliesmachineandsupply.com)

## Pineapple Peeler/Corer

To top and tail pineapple, place under the pusher and pull down. It cores and peels at the same time, giving you **perfectly peeled pineapples**. Available blades and pushers 3", 3 1/2" & 4". **Includes a 3 1/2" peeling/coring blade & pusher.**

**Features:**

- Peels and cores in one movement
- Clean and dismantle blade and pusher without tools
- Stainless steel construction

SPECIFICATIONS		
Model No.	Dimensions H x W x D	Ship Wt. (lbs.)
601570	28 1/2" x 17 3/4" x 15 1/2"	49

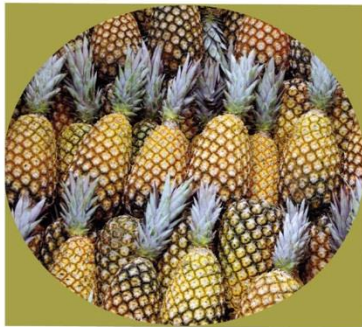

**Price**  
**\$ 1195.00**

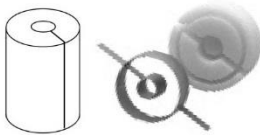

**All our peelers - whethr manual or air - Perfectly peels pineapple every time.**



**Pineapple Peeling Station**

## Pineapple Tube Corer/Peeler - Table-Top

Simple to use, this machine tubes, cores and peels pineapples. Just cut off both ends of the pineapple by hand, or with our manual Pineapple Top & Tailer (Pneumatic Top & Tailer also available), place it on the center of the base and pull the handle down. The pineapple is tubed, cored and peeled at the same time, giving you a perfectly peeled pineapple. Four (4) replaceable solid rubber suction cups keep the machine secure while tubing, coring and peeling. Different sized cutting assemblies are available 3", 3 1/2" and 4"

**Features:**

- Tubes, Peels and cores in one movement
- Stainless steel construction
- HDPE plastics (grip, base, slide blocks)
- Simple to operate, easy to clean
- Up to 10 to 15 pineapples per minute

**CALL FOR QUOTE**

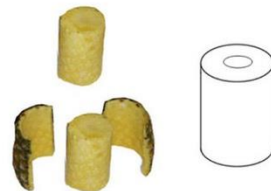

SPECIFICATIONS		
Model No.	Dimensions H x W x D	Ship Wt. (lbs.)
PPTTCP	19 1/2" x 10" x 23"	30

## Pineapple Top & Tailer - Manual

Cutting off the top and tail of your pineapple (perfectly straight) is a crucial step before you peel and core your pineapple. This machine **Tops and Tails** your pineapple with precision. Serrated holding strips and cutting knives keep the pineapple secure and the cut clean. Four (4) replaceable solid rubber suction cups keep the machine secure while topping and tailing.

### Features:

- Tops and tails in one movement
- Stainless steel construction
- HDPE plastics (grip, base, slide blocks)
- Fully Adjustable with Bottom Gage for Precision Cuts **Price \$ 1150.00**
- Up to 10 to 15 pineapples per minute
- Easy to operate & clean; all parts are replaceable

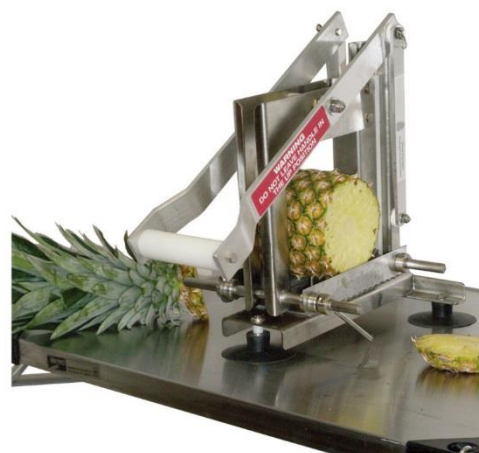

SPECIFICATIONS		
Model No.	Dimensions H x W x D	Ship Wt. (lbs.)
PPTT	15" x 17" x 12 1/2"	23

## Pineapple Slicer

Slices to any predetermined width that you require for your application. Simply place your pineapple on the cutting grill and pull down the handle. Serrated holding strips and cutting knives keep the pineapple secure and the cut clean and sharp.

### CALL FOR QUOTE

### Features:

- Stainless steel construction
- HDPE plastics
- Simple to operate, easy to clean
- 4 leg mount to HDPE base

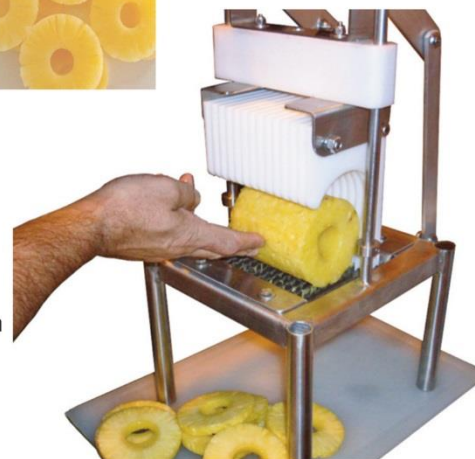

SPECIFICATIONS		
Model No.	Dimensions H x W x D	Ship Wt. (lbs.)
PPSlice	22" x 18" x 9"	22



## Pineapple Air "Tube Corer"/Peeler

This pneumatic corer peeler cores and peels in one swift movement, leaving the pineapple whole with the core intact ready for bagging or trayng. To operate: place top and tailed pineapple under pusher, push the two (safe feature) operator buttons to engage automatic air cylinder that then pushes the blades through the pineapple. Cores and peels perfect pineapple cylinder.

SPECIFICATIONS		
Model No.	Air Requirements	Dimensions H x W x D
	30cycl. 80 psi 8 cfm	69" x 28" x 31"

### CALL FOR QUOTE

**CALL 800-786-8455 or E-mail [info@charliesmachineandsupply.com](mailto:info@charliesmachineandsupply.com)**

# Industrial Food Processor-5000

Simply the best, largest and most versatile, rugged food processor available under \$15,000. Is designed for fast preparation of large food volumes--up to 5,000 lbs/hr. Slice, dice, shred, grate, julienne and make french fries. Able to process fruit, produce, mushrooms and more. Floor model has wheels for easy transport.

**CALL FOR QUOTE**

**Features:**

- On wheels for easy mobility
- Large feeders eliminate precutting
- More than 35 possible cutting tool variations
- Outstanding safety features
- Easy cleaning - can be hosed down
- Stainless steel and diecast aluminum



**Four Configurations to choose from:**

- 1) Feed Hopper
- 2) Manual Push Feed
- 3) Tube Feeder
- 4) Pneumatic (Air) Feed

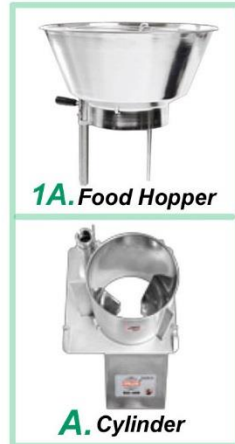

**A. Cylinder**



**2B. Manual Pusher**

**3B. Tube Feeder**

**4B. Pneumatic Pusher**

**B. Cylinder**

**SPECIFICATIONS**

Model No.	Power Requirements Electrical & Motor	Dimensions H x W x D	Ship Wt. (lbs.)
3002	220-240v 3ph 60hz 2hp - 2-speed 200/400rpm	66 1/2" x 27" x 39 3/4"	300



# Industrial Food Processor-1000

Tabletop model of the Industrial Food Processor with a **capacity of up to 1000 lbs/hr.** The forward leaning design puts the feed head and pusher handle close to the operator. The feed head can be set open for loading using both hands. This design makes it easy to work the machine at full capacity for long periods without operator fatigue. When the feeder is opened the machine stops. Close the feeder and the machine re-starts automatically. **Includes Tube Insert for Coin Cuts**

**Features:**

- Eliminates precutting
- 35 possible cutting tool variations
- Outstanding safety features
- Easy cleaning - can be hosed down
- Stainless steel and diecast aluminum

**Price \$ 3,995.00**

**SPECIFICATIONS**

Model No.	Power Requirements Electrical	Dimensions H x W x D	Ship Wt. (lbs.)
40425	110-120v 1ph 60hz or 220-240v 1ph 60hz	24" x 13" x 13"	78

# Industrial Food Processor Replacement Blades, Attachments and Accessories

Cutting Blades for IFP-5000 and IFP-1000

**NEW! ALL STAINLESS STEEL CUTTING PLATES**

Stainless Steel Slicers for all products		
Cut Size	Part No	Price
0.5 mm (1/64")	63082	485.00
1 mm (1/32")	63081	485.00
1.5 mm (1/16")	63023	485.00
2 mm (3/32")	63026	485.00
3 mm (1/8")	63045	485.00
4 mm (5/32")	63056	485.00
5 mm (7/32")	63083	485.00
6 mm (1/4")	63046	485.00
7 mm (9/32")	63084	485.00
8 mm (5/16")	63042	485.00
9 mm (11/32")	63085	485.00
10 mm (3/8")	63033	485.00



Slicer: 0.5, 1, 1.5, 2, 3, 4, 5, 6, 7, 8, 9 and 10 mm

Slices firm products, such as root vegetables, onions, leek, bell pepper, apple, citrus fruit and cucumber. Shreds cabbage. From 4 mm upwards, slice tomato, bananas, mushrooms and shreds lettuce and Chinese cabbage. In combination with suitable dicing grid the 4 mm slicer chops onions.

Aluminum Slicers		
Type	Part No	Price
Dicing Cutter 12.5mm	62216	395.00
Fine Cut Slicer 14 mm	62320	565.00
Fine Cut Slicer 20 mm	62322	565.00
Standard Slicer 15 mm	62255	565.00
Standard Slicer 20 mm	62256	565.00

Note: Use Fine Cut Slicers for softer products with higher water content. Use Standard Slicers for harder.

Stainless Steel Crimping Slicers		
Cut Size	Part No	Price
2 mm (3/32")	63342	485.00
3 mm (1/8")	63343	485.00
4 mm (5/32")	63074	485.00
5 mm (7/32")	63345	485.00
6 mm (1/4")	63039	485.00



Dicing Cutter: 12.5 mm

Dices root vegetables, potatoes, cabbage for soups, etc., blanched potatoes for potato salads, etc. Dices in combination with a suitable dicing grid (see below)



Fine Cut Slicer: 14 and 20 mm

Slices firm and soft products, such as root vegetables, onion, leek, bell pepper, apple, citrus fruit and cucumber. Shreds cabbage. 0.5 mm for Parmesan "flakes". From 4 mm upwards, slice tomato, bananas, mushrooms and shreds lettuce and Chinese cabbage. In combination with suitable dicing grid the 4 mm slicer chops onions.



Standard Slicer: 15 and 20 mm

Slices firm products, such as root vegetables. Dices in combination with a suitable dicing grid (see below)

Stainless Steel Julienne Cutters		
Cut Size	Part No	Price
2 x 2 mm	63031	515.00
2 x 6 mm	63348	515.00
3 x 3 mm	63349	515.00
4 x 4 mm	63061	515.00
6 x 6 mm	63065	515.00
8 x 8 mm	63073	515.00
10 x 10 mm	63080	515.00



Crimping Slicer: 4 and 6 mm (Wavy or Crinkle Cut)

For ripple slicing of beetroot, cucumber, carrots, etc.



Julienne Cutters: 2x2, 2.5x2.5, 2x6, 4x4, 6x6, 8x8 and 10x10 mm

For soups, salads etc. 2x2 mm for julienne potatoes and carrots, 2.5x6 mm for shredded cabbage. 8x8 or 10x10 for curved potato chips/French fries.

Cast Aluminum Dicing Grids		
Cut Size	Part No	Price
6.25x6.25mm (1/4")	62400	590.00
8 x 8 mm (5/16")	62401	590.00
10 x 10 mm (3/8")	62402	590.00
12.5x12.5mm (1/2")	62403	590.00
15 x 15 mm (5/8")*	62407	590.00
20 x 20 mm (3/4")*	62408	590.00
25 x 25 mm (1")*	62409	590.00
French Fry Grid **	62624	620.00
10x10mm (3/8" x 3/8")		

\*Denotes Low Grid- to be used only with Fine Cut Slicer 14 or 20 mm(see Page 1).



Dicing Grids: 6.25x6.25, 7.5x7.5, 10x10, 12.5x12.5, 15x15, 20x20 and 25x25 mm

Dices root vegetables, fruit, potatoes, cabbage, sweeties, carrots, cucumbers, tomatoes, apples, etc., in combination with a suitable standard, slicer, dicing cutter or fine cut slicer.



\*\*Potato Chip/French Fry Grid: 10 mm x 10 mm x var. length

Cuts straight potato chips in combination with the 10mm fine cut slicer 3/8" x 3/8" x Length of Potato or Sweet Potato

Soft Dicing Sets		
Dice Size	Part No	Price
8x8 mm (5/16x5/16")	62591	1,175.00
10x10 mm (3/8x3/8")	62590	1,175.00
12x12 mm (1/2x1/2")	62589	1,175.00
15x15 mm (5/8x5/8")	62588	1,175.00



Soft Dicing: 8x8x8, 10x10x10, and 12x12x12 mm

Dicing sets incl. two cutting tools for gentle dicing of products like tomatoes, onions, bell peppers, bananas and strawberries.

**Soft Dicing Defined:**

For Perfect Dicing of difficult fruits and vegetables. The knives on both the slicer assembly and grid assembly are extremely sharp (sharper than standard slicers and grids), and made of stronger metal. The unique design of the slicer (bevel) is developed to more effectively push the product through the grid resulting in a more perfectly chopped (not crushed) precision cut.

Type	Part No	Price
Fine Grater	62637	485.00
Extra Fine Grater	62638	485.00
Hard Cheese Grater	62639	485.00



Fine Grater, fine

Grates raw potatoes for potato pancakes. Grates hard/dry cheese to a powder, such as Parmesan for pasta. grates dry bread. grates horse radish into sauce.



Fine Grater, extra fine

Grates radish for the Japanese Cuisine as well as carrots into "purée". Grates dry bread.



Hard Cheese Grater

Ideal for grating hard cheese such as parmesan.

Stainless Steel Raw Food Shredders		
Cut Size	Part No	Price
1.5 mm (1/16")	62630	485.00
2 mm (3/32")	62631	485.00
3 mm (1/8")	62632	485.00
4.5 mm (3/16")	62633	485.00
6 mm (1/4")	62634	485.00
8 mm (5/16")	62635	485.00
10 mm (3/8")	62636	485.00



Grater/Shredder 1.5, 2, 3, 4.5, 6, 8 and 10 mm

Grates carrots and cabbage for raw salads. Grates nuts, almonds and dry bread. The 6 or 8 mm is commonly used for grating pizza cheese and shredding cabbage.

Replacement Ejector Plate - Model No. 3086 \$68.00

## ATTACHMENTS



**1A. Feed Hopper**  
Continuous bucket feeding/cutting of potatoes, onions, mushrooms, etc.  
Complete with Feed Cylinder **A.**

Model No. 33329 - \$ 4,345.00

Type **A.**

**2B. Push Feed Attachment, manually operated**  
Fast and easy feeding of cabbage, lettuce, carrots and other foods that require feed pressure. Needs to be coupled with Feed Cylinder - Model

Model No. 33331 - \$ 1,755.00

**B Feed Cylinder**  
Type **A.** included w/Feed Hopper  
Type **B.**-use with manual pusher, pneumatic pusher and 4-tube insert.

Model No. 3035 - \$ 1,795.00 Type **B.**

**3B. 4-Tube Insert**  
For full control during oriented cutting of cucumbers, leeks, tomatoes, citrus fruit, etc. Use with Feed Cylinder

Model No. 33330 - \$ 1,415.00

**4B. Push Feed Attachment, pneumatic** For automatic feeding of cabbage, lettuce, carrots and other foods that require feed pressure. Use with Feed Cylinder

Model No.33332- \$ 5,610.00

**Stainless Steel Cart with Container**  
Locking Casters  
Adjustable Height  
Model No. 40721  
\$970.00



## Multi-Use Hand Cutter

Over the years, there have been many copies, but the Multi-Use Hand Cutter remains the industry's first choice. This durable and low-maintenance design is available for the countertop or wall mounting.

Available with a wide selection of cutting heads and accessories, making it simpler than ever to wedge, cut, dice, julienne, shred, cube or slice fruits, vegetables and cheeses into pieces of various thicknesses and shapes.

**Includes blade head & pusher.**

(See page 13 for pricing of blades and cutting heads)

**Features:**

- Lightweight
- Easy cleaning
- Safe and easy to operate
- Hand pull down plunger

**Price \$ 399.00**



**300 Series**

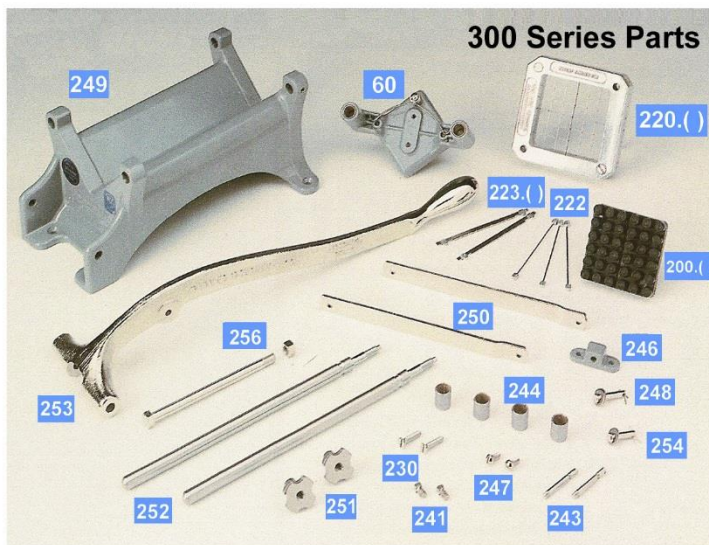

The versatile  
and reliable  
**Multi-Purpose  
Hand Cutter**

can do  
all of

these cuts:



**Stick Cuts, Julienne Cuts, Slice Cuts,  
Shoestring Cuts, Wedge Cuts & More!**

## Multi-Use Air-Powered Cutter

Perfect for all-purpose processing and pre-cutting of all kinds. Like its hand-operated counterpart, the Multi-Use Air-Powered Cutter can be used on the countertop or wall mounted. It shares all the standard cutting heads with the hand-operated unit. **Includes blade head & pusher.** (See page 13 for pricing of blades and cutting heads.)

**Features:**

- Lightweight
- Easy cleaning
- Safe and easy to operate
- Guard rail safety design

**Price \$ 2,995.00**



**400 Series**

**FULLY ASSEMBLED MACHINE, BLADES & PARTS PRICE LIST**

**300 Series - Multi-Use Hand Cutter**

Part No.	Description	Price
300	Without Cutting Head/Pusher Block	\$ 305.00
300.1	With 1/8" Head	\$ 430.00
300.2	With 3/16" Head	\$ 399.00
300.3	With 1/4" Head	\$ 399.00
300.4	With 3/8" Head	\$ 399.00
300.5	With 1/2" Head	\$ 399.00
300.6	With 5/8" Head	\$ 399.00
300.A	Slicer 1/8" Plain Blade	\$ 450.00
300.B	Slicer 1/4" Plain Blade	\$ 430.00
300.C	Slicer 3/8" Plain Blade	\$ 410.00
300.D	Slicer 1/2" Plain Blade	\$ 410.00
300.E	Slicer 1/8" Serrated Blade	\$ 505.00
300.F	Slicer 1/4" Serrated Blade	\$ 490.00
300.G	Slicer 3/8" Serrated Blade	\$ 485.00
300.H	Slicer 1/2" Serrated Blade	\$ 486.00
300.W	4 Segment Wedger	\$ 399.00
300.X	6 Segment Wedger	\$ 410.00
300.Y	8 Segment Wedger	\$ 410.00

**400.(\_) Multi-Purpose Air Cutter \$2,995.00**

**300 Series - CUTTING HEADS**

Part No.	Description	Price
220.1	Cutting Head 1/8"	\$ 128.00
220.2	Cutting Head 3/16"	\$ 96.00
220.3	Cutting Head 1/4"	\$ 96.00
220.4	Cutting Head 3/8"	\$ 96.00
220.5	Cutting Head 1/2"	\$ 96.00
220.6	Cutting Head 5/8"	\$ 96.00
220.A	Slicing Heads 1/8" Plain Blade	\$ 146.00
220.B	Slicing Heads 1/4" Plain Blade	\$ 134.00
220.C	Slicing Heads 3/8" Plain Blade	\$ 134.00
220.D	Slicing Heads 1/2" Plain Blade	\$ 134.00
220.E	Slicing Heads 1/8" Serrated Blade	\$ 274.00
220.F	Slicing Heads 1/4" Serrated Blade	\$ 216.00
220.G	Slicing Heads 3/8" Serrated Blade	\$ 204.00
220.H	Slicing Heads 1/2" Serrated Blade	\$ 204.00
220.W	Cutting Head 4 Segment Wedger	\$ 93.00
220.X	Cutting Head 6 Segment Wedger	\$ 96.00
220.Y	Cutting Head 8 Segment Wedger	\$ 105.00

**300 Series - BLADES**

Part No.	Description	Price
222	Small Blades (dozen pkg.)	\$ 26.00
223.1	Spacer Blades 1/8" (set of 2)	\$ 14.00
223.2	Spacer Blades 3/16" (set of 2)	\$ 14.00
223.3	Spacer Blades 1/4" (set of 2)	\$ 14.00
223.4	Spacer Blades 3/8" (set of 2)	\$ 14.00
223.5	Spacer Blades 1/2" (set of 2)	\$ 14.00
223.6	Spacer Blades 5/8" (set of 2)	\$ 14.00
223.A	Blades Slicing Plain	\$ 8.00
223.E	Blades Slicing Serrated	\$ 19.00
223.W	Blades 4 or 8 Segmented	\$ 15.00
223.X	Blades 6 Segmented (set of 3)	\$ 22.00

**300 Series - PUSHER BLOCKS**

Part No.	Description	Price
200.1	Pusher Block 1/8"	\$ 15.00
200.2	Pusher Block 3/16"	\$ 15.00
200.3	Pusher Block 1/4"	\$ 15.00
200.4	Pusher Block 3/8"	\$ 15.00
200.5	Pusher Block 1/2"	\$ 15.00
200.6	Pusher Block 5/8"	\$ 15.00
200.A	Pusher Block Slicing Flat	\$ 19.00
200.B	Pusher Block Slicing Ridged 1/8"	\$ 19.00
200.C	Pusher Block Slicing Ridged 1/4"	\$ 19.00
200.W	Pusher Block 4 Segment Wedger	\$ 19.00
200.X	Pusher Block 6 Segment Wedger	\$ 19.00
200.Y	Pusher Block 8 Segment Wedger	\$ 19.00

**300 Series - PARTS**

Part No.	Description	Price
10	Repair Kit, Slide Rod	\$ 170.00
20	Screw Bolt and Link Kit	\$ 92.00
30	Link Parts Kit	\$ 42.00
230	Cutting Head Screws (set of 2)	\$ 3.00
241	Set Screws (set of 2)	\$ 3.00
243A	Pusher Block Pins (2)	\$ 5.00
244	Bronze Bearing Kit (set of 2)	\$ 14.00
60	Slide Casting with Bearing	\$ 85.00
246	Link Bearing Block	\$ 12.00
249	Base Casting	\$ 145.00
252	Slide Rods, Stainless Steel (2)	\$ 67.00
253	Handle	\$ 97.00
256	Handle Bolt Assembly	\$ 8.00
251	Knobs (set of 2)	\$ 7.00
70	Spring Rebuild Kit	\$ 8.00
TB 100	Wall Bracket	\$ 289.00

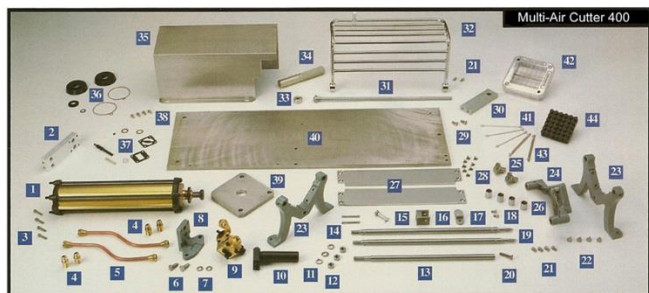

Parts for Multi-Purpose Air Cutter - 400 Series. Call for Quote

**CALL 800-786-8455 or E-mail [info@charliesmachineandsupply.com](mailto:info@charliesmachineandsupply.com)**

## Abrasive Roll Peeler

Is an excellent machine for peeling and washing various types of root vegetables including potatoes and carrots. It comes equipped with 4, 6 or 8 rollers. The rolls are mounted parallel with the product flow for optimum results. Product can be fed continuously or in batch loads into the top in-feed hopper at the back end. For rinsing peel and brush washing, a SS water pipe header with spray nozzles are located overhead.

**Features:**

- Stainless steel construction
- Stainless steel discharge gate.
- Variable speed controller.
- Lubrication cluster intakes for easy maintenance.

**CALL FOR QUOTE**

SPECIFICATIONS		
Model No.	Power Requirements Electrical	Dimensions H x D x L
G-RL-PL	208/230/460v 3ph	36" x 24 x 96"



5, 7 or 8  
Abrasive Roll  
or Brush Roll  
Peelers

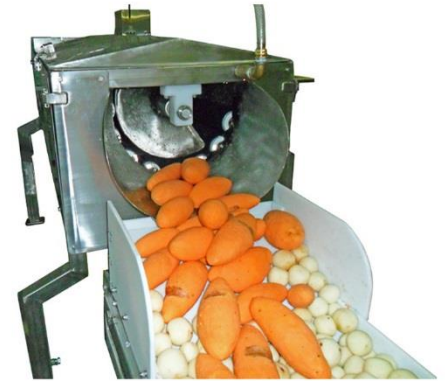

## 60 lb. Abrasive Batch Peeler

Peels up to 60 lbs of potatoes in approximately three minutes. This system removes peels using a water rinse-off inlet line located inside the peeling chamber. Potatoes are clean and ready for cutting, eliminating the laborious task of hand peeled potatoes or refilling the chamber on a more frequent basis. Extra heavy duty food safe design for the most demanding applications.

**Features:**

- Stainless steel construction
- Large drum for big batches
- Capacity is approximately 60 pounds

**CALL FOR QUOTE**

SPECIFICATIONS			
Model No.	Power Requirements Electrical	Dimensions H x D x L	Ship Wt. (lbs.)
PLR 60	120v 1ph 2hp	51.25" x 29.5 x 29.5"	590

## 20 lb. Abrasive Batch Peeler

Brings economy and efficiency in preparing potatoes, carrots and other root vegetables. Hand peeling can take up to half an hour to peel 20 pounds of potatoes with up to 35% waste. The Potato & Carrot Peeler can do the same job in 2 to 3 minutes and cut the waste to less than 10%. **Includes Durable Peeling Disc**

**Price \$ 1,995.00**

**Features:**

- Stainless steel construction
- Built-in timer prevents over-peeling and waste
- Quick easy lock-door
- Extended discharge chute, minimizes splashing
- Operates on mobile stand, counter or table

SPECIFICATIONS			
Model No.	Power Requirements Electrical	Dimensions H x D	Ship Wt. (lbs.)
1120500	115v AC/60-1 - 1/3hp	27" x 15 1/4"	86



**EQUIPMENT STANDS** - Stainless Steel with locking casters are available

[www.charliesmachineandsupply.com](http://www.charliesmachineandsupply.com)



## air-driven Broccoli Floretter

Easy to operate and very reliable, the air-driven Broccoli Floret Machine is 2 to 4 times faster than manual cutting. Simply load two heads of broccoli into the machine slots and push the buttons. The machine does the rest, removing unwanted stems and cutting the head into perfect florets. The air-driven Broccoli Floret Machine is designed so the user has to use both hands to load the broccoli heads and then must use both hands to activate the machine. **Florettes drop into a tote or conveyor. Also available in a Single Head**

### Features:

- Stainless Steel Construction
- Wash-down Safe
- Increases Yield
- Button Operated

**CALL FOR QUOTE**

SPECIFICATIONS			
Model No.	Power Requirements Air	Dimensions H x W x D	Ship Wt. (lbs.)
ERBMF2	40 cycles 100 psi 16 cfm	12" x 12" x 18"	60

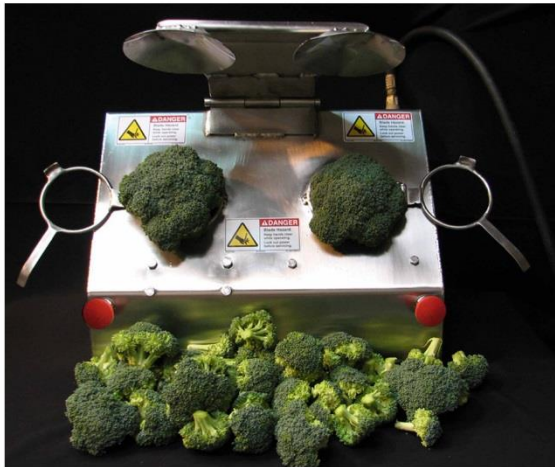

One person on the production line can cut by hand, approximately 10 heads of broccoli per minute while the dual head air-driven Broccoli Floretter can cut approximately 40 heads per minute.

### Broccoli Floret Sorting Conveyor

with Buffalo Grill Size Separator. Florets fall directly onto Buffalo Grill (small piece separator) small pieces fall through into tub, and larger sized pieces fall down Grill Chute onto Conveyor for Inspection.

### Features:

- Stainless Steel construction
- 3" tall Side Guide Rails, Protective Side Panels
- Series 800 Interlock Belt Food Grade Wash Safe
- Discharge Chute
- Electrical Panel with VFD Adjustable Speed Motor

**CALL FOR QUOTE**

Includes: Stand for Broccoli Floretter with mount elevated for easy access to side table. Feet are adjustable height.



### Broccoli Station Floretter Stand

- Stainless Steel. 36" x 24" x 22"

Ship Wt. 27 lbs. Does not include brute or tote.

Ship Dim. 36" x 24" x 6"



26" wide x 44" Tall x 120" long



**CALL 800-786-8455 or E-mail [info@charliesmachineandsupply.com](mailto:info@charliesmachineandsupply.com)**

## Carousel Slicer - Dual Blade

Great for onion and other vegetables or fruit. Peeled product is placed in top-holes; top-holes rotate to safety guard and are then dropped to slicer blades. The produce is perfectly sliced to your desired thickness. This Carousel Slicer can have from 8 to 12 holes, and holes range from 3" to 6" according to your needs. Easily adjustable from 1/8" to 3/4" slice thickness. The slicing knives are 10" in dia. and rotate at 200 r.p.m. **Each slicer top is built according to your needs. ALSO AVAILABLE - SINGLE BLADE CAROUSEL SLICER**

**Features:**

- 304 stainless steel construction
- 400 stainless steel slicing knives
- Fully adjustable 1/8" to 3/4" slice thickness
- Slices up to 780 lbs. per hour

**CALL FOR QUOTE**

**PERFECT FOR ONIONS  
AND OTHER  
VEGETABLES OR FRUIT**

**SPECIFICATIONS**

Model No.	Power Requirements Electrical	Dimensions H x W x D
G-OS	120v - 1 phase	52" x 36" x 36"



## Onion Slicer

Slices perfect onions without crushing or bruising them. It also slices potatoes for cottage fries, squash, lemons, limes, oranges and other firm vegetables and fruits. Great for dried apple ring slices. Blade sizes 3/16", 1/4", 3/8" or 1/2" cut for jumbo onions. Model No. **ON-SLCR**

**Price \$ 475.00**

## Manual Onion Top and Tail

This "V" shaped blade head allows onions to be topped and tailed. Slide through to cut the top - turn onion over and cut slide through again to cut the bottom. Control from 1/2 to 3/8". Easily sits on a barrel (not included) Replacement knife available. Model No. **ON-TTM**



**Price \$ 695.00**



## Onion Peeler

Peels onions gently and accurately. The cutting bed cuts the peels loose, then the rollers and blowing air strips them away. There is no water used in the peeling process. The onions are beautifully peeled and ready for use. This peeler allows you to top and tail before you peel, or you can top and tail after you peel for an increased yield. The Onion Peeler is easy to operate, reliable and efficient.

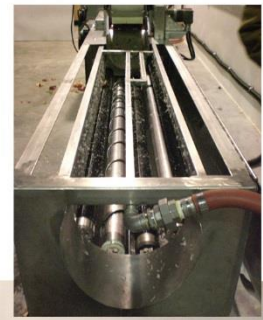

**CALL FOR QUOTE**

### Features:

- 304 stainless steel construction
- Fully adjustable speed control
- Electric drive
- Peels up to 4,000 lbs. per hour

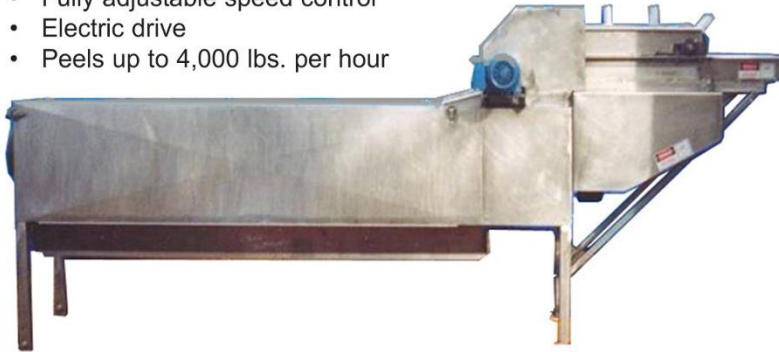

### SPECIFICATIONS

Model No.	Power Requirements Electrical	Dimensions H x W x D	Air Requirements
ON-PE	330v/460v 3 phase	96 1/2" x 36" x 37"	90 p.s.i. at 200 c.f.m.

**GO TO OUR WEBSITE FOR VIDEO DEMO**

## Onion Top and Tail Processor

**Tops and tails any size onion** - from PeeWee to Colossal sizes. The Onion Top and Tailer is easy to adjust to accept Onions from 2" to 6" in diameter with little or no adjustments to the processor. It can top and tail about 80 onions per minute with specially designed cups that hold onions for topping and tailing while preserving the skin without creating cuts or groves.



**CALL FOR QUOTE**

### Features:

- Stainless steel construction
- Wash-down safe
- Labor saving
- Peels up to 80 onions per minute
- Safety switches

### SPECIFICATIONS

Model No.	Power Requirements Electrical	Dimensions H x W x D
T-OPP	330/460v - 3 phase 2 hp	60" x 36" x 96"

**CALL 800-786-8455 or E-mail [info@charliesmachineandsupply.com](mailto:info@charliesmachineandsupply.com)**

## Shaker Conveyor

Is great for removing bugs, small leaves, cotyledons & small fines. Are you a small organic farmer or processor who washes and cleans spinach, lettuce and baby leaf vegetables? This shaker conveyor is designed to remove most of the small unwanted material, including, small twigs, undersized leaves and pesky little bugs. As your produce moves down the conveyor, a custom selected open hole mesh link belt is shaken up and down, gently tossing the produce, enabling the dislodgement and removal of unwanted material. Effective and Efficient.

**Features:**

- All Stainless Steel construction
- Stainless steel mesh belting 1" octagon shaped holes or custom size
- Lifts product up and down and shakes off unwanted small pieces of debris.
- Also used to shake the hole out of onion rings.

**CALL FOR QUOTE**



**SPECIFICATIONS**

Model No.	Power Requirements Electrical	Dimensions H x W x L
G-SHKR	220v 3ph 60 Hz	30" x 36" x 120"



## Sizing / Grading - Vibrating Conveyor

Removes small fines and smaller sized pieces that don't meet your required specification. Sizing plates can be removed and replaced with larger or smaller screens. Capacities can range from 500 to 1,500 lbs per hour.

Custom Built for any size project.



## Increment Cutter

Segments carrots and celery up to 1000 lbs. per hour. Great for bell peppers and collard greens. The rotary blade system prevents bruising and breakage; 32" width allows operators to work from both sides simultaneously for increased productivity. Replacement blades are available.

**Features:**

- Standard 4" cut (other optional length sizes 2", 3", 3-1/2", 5")
- 304 stainless steel construction
- Self lubricated gearhead
- FDA approved flat-top flighted plastic belting
- Wash-down composite bearings
- Wash-down duty motor
- 6" adjustable legs for easy leveling of cutter
- Safety guard with micro switch
- Stop switch on each side

**CALL FOR QUOTE**



Casters Optional

**SPECIFICATIONS**

Model No.	Power Requirements Electrical	Dimensions H x W x L
R-DIC	480v 3 phase 60Hz	55" x 40" x 94"

## Vegetable & Fruit Wash

Versatile and inexpensive, this Stainless Steel wash is designed to handle a variety of products. Circular flowing water is controlled by valves on the sides of the tank, allowing you to increase or decrease the intensity of flow for a more thorough wash. Air Holes on the inside of the tank assist the spray nozzles to obtain a more effective circulation of product. The open hole Flow-through Belt and Discharge Conveyor easily lifts out for cleaning. At the bottom of the tank is a lift-out filter that removes most small particles from the wash. An Over-Flow Side Screen Filter also helps in the removal of small unwanted material. Capacity: 880-1100 bls/hour



**CALL FOR QUOTE**

SPECIFICATIONS		
Model No.	Power Requirements Electrical	Dimensions H x W x L
VFWASH	220v 3 phase 60Hz	53" x 36" x 118"

## Single Washer

Wash System, Single Tank (tank width is 24") with 18" wide KVP 38% Open Mesh Conveyor Belt, Hydrosive Filtering System, Stainless Steel Sanitary Spray Bar Tubing, Stainless Steel Pipe Fittings with Removable Nozzles for Cleaning, 1Hp Stainless Steel Sanitary Pump. 1/2 Hp Conveyor Motor and Gearbox housed in Stainless Steel Box, Lift-Out Conveyor for Washing, Hookup Inlet for Cold Water Source. Sanitation in-line dispenser is optional using Klorman Calcium Hypochlorite dispenser built-within the Spray Bar System or using Pulse System 3 (ORP & pH) Automated Sanitation system.



We can install various Sanitation Systems



Optional Side Chill Tank

**Dimensions:** 120" x 24" x 30"  
(overall width 32" with motors)  
Electrical 230V - 3 phase or 460V - 3 phase.

**CALL FOR QUOTE**

SPECIFICATIONS		
Model No.	Power Requirements Electrical	Dimensions. L x D x W
G-SWASH	230v 3Ph 1hp	120" x 24" x 30"

**CALL 800-786-8455 or E-mail [info@charliesmachineandsupply.com](mailto:info@charliesmachineandsupply.com)**

## Spray & Wash Conveyor for Vegetables & Fruits w/Chlorination System

This low cost system is designed to wash & sanitize a wide range of products. It also provides room for product inspection. As product moves along the conveyor; it is inspected and then moves under overhead spray bars and is sprayed with the chlorinated water to sanitize and to remove particles of dirt, bugs and other unwanted material. The flow control valves allow for fully controllable spray for just the right wash (gentle or strong spray) and will provide ample water flow to do its job.



**Spray Wash Conveyor with Air Knife and Blower**

The Spray & Wash Conveyor System will spray wash most products, especially those that tend to float in other pan wash systems. (Spray bars can be mounted above and below the belt for heavier wash requirements).

**Custom built Spray Wash & Dry System to meet your requirements**



**CALL FOR QUOTE**

**Features:**

- Custom Built to your needs
- Heavy-duty Stainless Steel construction
- Extra hookup for wash-down hose
- Variable Speed Drive with Control Panel
- KVP Belt with 30% open area
- Built-in sanitation system

**SPECIFICATIONS**

Model No.	Power Requirements Electrical	Dimensions H x W x L	Ship Wt. (lbs.)
SPR-WSH	230v/460v 3 phase 1 hp	34" x 18" x 144"	400

## Double-Wash

This economical wash system is designed to meet the needs of processors who require more frequent, smaller type loads yet can handle larger size jobs when required. Originally designed for more effectively washing chopped or leaf lettuce, this two-wash tank, two-conveyor system with a separate final rinse will gently roll, separate, clean and sanitize most produce. It



**Four Step - Wash Rinse Wash Rinse**

includes our standard Klorman Calcium Hypochlorite Dispenser for sanitizing your produce. The Double-Wash is only 11' long and 2' wide. This machine is equipped with a quick remove dewatering pan and filter screen that remove bugs and other unwanted material. Each of the two conveyors lift out for easy cleaning.

**CALL FOR QUOTE**

**Features:**

- Heavy-Duty Stainless Steel
- Single Tank Version also available
- Flow control valves
- Filter Screen
- Spray bars are rotatable.
- Stainless Steel Pump
- Ideal for Chopped or Loose Leaf Lettuce
- Conveyors lift out for cleaning
- Extended width and length available
- Optional Sanitation Systems

**Double Wash with Blue Belt and Air Knives**



## Melon & Fruit Washer

Designed for washing and sanitizing the outside of melons. Wash travel length is 16' (two 8' lanes) with stainless steel spray bars, adjustable spray nozzles and push-down paddle system that completely submerge the melons for better sanitation. Dwell time is 60 to 90 seconds. This system includes our built-in Dispenser that uses Calcium Hypochlorite cartridges (see pg 22) for sanitizing. Once fully washed, the melons are removed manually on the discharge side.

**Capacity: approximately 15 – 20 melons per minute.**

*Larger Systems Available*

### Features:

- Stainless Steel construction
- Circulating Pump w/TEFC motor
- Jet Spray for maximum cleaning
- Submersion paddle system
- Built-in sanitation system

**CALL FOR QUOTE**



### SPECIFICATIONS

Model No.	Power Requirements Electrical	Dimensions H x W x L	Ship Wt. (lbs.)
GER-MW	230v 3 phase 2 hp pump motor	34" x 52" x 108"	800

## Basket Washer

Washes and removes stones and sand from virtually all leafy products. Product is placed into a 20 Gallon Basket where gushing water washes the product and dislodge all foreign particles; this process is done in 3 minutes cycles. A hydrosive filter removes unwanted particles from the circulating water. 304 stainless steel construction. Comes with a bucket drip stand & pan

**CALL FOR QUOTE**

### Built-in Sanitation Systems Available

- Dimensions: 72" L x 30" W x 72" H
- Capacity: 50 to 100 lbs per cycle.  
1000 to 1200 lbs. per hour.

*Door Opens for easy access*



## Dip Tank

This stainless steel soak tank or holding tank is ideal for soaking vegetables and fruits. You can use it for peeled potatoes or carrots and is great for small batches of cut fruit. Use a mesh bag or a plastic container with holes to put in the produce and take out. It is very versatile and can be used with many different products.

**CALL FOR QUOTE**



## Continuous Feed Air Knife Drying Conveyor

is a **CUSTOM BUILT** drying system for Lettuce and Mix Products - Adjustable and designed with 1-3 Belt turnovers to flip product, Complete with 3-5 Air Knife Stations. Variable speed belt motor; VFD on a 5-7.5 hp TEFC Fan Blower; 1/2 hp TEFC VFD Conveyor Motor; Gearbox & Electrical On/Off Panel; Composite Bearings; Fiberglass Control Panel Box. A Flex or Lexon Cover is over Air Knives to contain flying pieces.

**Power Requirements: 230/460 3ph 60Hz**

**CALL FOR QUOTE**



**CALL FOR QUOTE**

## Industrial Food Dryer

This dryer is designed to dry 40 to 50 lbs. per load of spinach, cole slaw, lettuce, carrots, celery and other vegetables. Our **New Digital Controller** allows you to control the spin time and speed - from 500 rpm to 900 rpm - depending on your product. **Includes 20 gallon standard white basket.** Extra Baskets Available



**New!  
Digital Control  
Panel**

**Features:**

- 304 stainless steel construction
- Wash-down safe duty motor
- Non-contact safety interlock switch
- Water is channeled to 2" npt drain
- Adjustable legs

- 20 Gallon Basket with 1/4" holes

## 32 Gallon Industrial Dryer



**SPECIFICATIONS**

Model No.	Power Requirements Electrical	Dimensions H x D	Ship Wt. (lbs.)
DRY-20GAL	208v / 230v - 1 hp 3 phase stainless steel motor	36" x 39"	350

**SPECIFICATIONS**

ISO-DRY	208V-230V 3 Ph
44" x 44"D	700 lbs.

## Lighter Duty Vegetable Dryer



Perfect for small runs of vegetables. 20 to 40 lbs per load. Great for leafy greens. Stainless steel body and lid. **Includes 20 gallon white basket.**

**SPECIFICATIONS**

Model No.	Electrical Requirements	Dimensions H x W x D	Ship Wt. (lbs.)
601559	110v	32 1/2" x 27" x 27"	80

**Price \$ 2,595.00**

[www.charliesmachineandsupply.com](http://www.charliesmachineandsupply.com)



## Pack Table with Digital Scales

Our Pack Tables with scales is designed with a remote digital display mounted on the top to show the weight as the operator bags. Easy to use. Place the bag over the 6" funnel and the bag sits on the scale. The operator then pulls product into the discharge funnel until the remote digital display reaches the desired weight.

**Includes digital remote display scales.**

**Available in One, Three, Four or Six Hole.  
We can customize to your needs**

### Features:

- 304 stainless steel
- Adjustable scale platforms for most bag heights
- Digital scales with remote mount displays
- Funnels (chutes) can be made in almost any size
- Air clamps (optional) to hold bags
- 6" adjustable legs



SPECIFICATIONS		
Model No.	Dimensions H x W x D	Ship Wt. (lbs.)
DP-2	40" x 72" x 54"	200



## Rotary Turntable "Lazy Susan"

**CHECK OUT OUR WEBSITE  
FOR MORE PRODUCTS AND  
VIDEO DEMOS**

**MADE IN THE USA!**



## Brick Stick Pack

Easy and simple way to "brick" pack celery and carrots. To operate, load product and sort in tray, pull bag over tray and slide product into bag, then slide bag off tray to create the brick pack. Custom built to fit your product.

### Features:

- Stainless steel
- Easy to operate & clean
- Fits onto Countertop
- Adjustable legs



Great for Carrots  
or Celery

**CALL FOR QUOTE**

**CALL 800-786-8455 or E-mail [info@charliesmachineandsupply.com](mailto:info@charliesmachineandsupply.com)**

## Klorman Chlorine Dispenser - for Waterlines



An in-line dispenser that puts dry Calcium Hypochlorite directly into the water line. Because the **Klorman** utilizes calcium as a vehicle for the chlorine, it is self-buffering when added to water. This keeps the pH of the water at a level where more active chlorine is available for disinfecting. As a calcium-based product, it actually participates in structurally strengthening cell walls while occupying and protecting vulnerable enzyme sites from pathogens. The **Klorman** also brightens tissue color, firms texture, and preserves and extends the shelf life of all your fresh cut produce. Based on research at the University of Illinois, the **Klorman** system has proven to be 120 times more effective in killing bacteria than liquid bleach.

### Features:

- One step wash-down operation
- No bleach mixing - pH stable
- No harmful chemical residues
- Non-corrosive - No chlorine odor
- Pressure range 5 psi - 60 psi

### Prices:

Dispenser: KSD100 \$ 265.00 ea.  
 Cartridges: HSC100 \$ 495.00 ea. case  
 (16 Cartridges per Case) 1/2 - 1 year supply

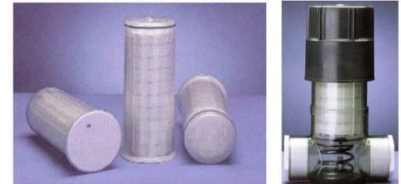

## Metal Detector

One of the better metal detectors we have come across in a long time. It can be custom designed to fit your needs



### Features:

- 99 produce items can be pre-programmed in memory
- 2 kinds of screen language
- Self-diagnosis, automatic fault shut down
- Optional Alarms-sound/light
- Conveyor belt stop
- Interface to other equipment

**Performance and characteristics:** Various measures for anti-interference, like noises and outside interferences. Large screen display, easier to operate. Stainless steel framework, IP65, in line with the hygiene requirements. Workable in dry or wet environment, applicable for automatically detecting different products.

CALL FOR QUOTE

## Band Sealer w/ Conveyor

Change from one size bag to another with no down time. Feed continuously with up to 750 inches per minute. Seal 3/4" or 3/8" with an optional Ink or Emboss Printer.



### Features:

- Feeds L to R or R to L
- Teflon fabric bands
- Digital read to 600 deg.
- Variable speed
- Optional trimmers
- User Friendly

Print Code Sample

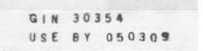

CALL FOR QUOTE

## Vertical Form, Fill Seal Bagger

10 or 14 Bucket Loader



Great for bagging apple wedges or potato chips and a multitude of dry and process foods and fresh foods. Will bag between 40 to 120 bags a minute depending on your requirements.

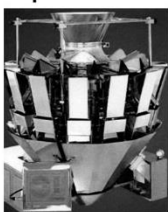

Contact Us for more Information



**Conveyors:** all shapes, sizes and colors: incline, inspect, turn, sort, blue, green or white. Contact us for more Information.



www.charliesmachineandsupply.com

## Horizontal Band Sealer w/Built-In Code Printer

This sealer comes standard with Code Printer and Built-in Conveyor. The Tilting Seal Head feature allows tilt up to a 30-degree angle, which makes this sealer ideal for most any produce including those with some liquid in the package. It has a full range of adjustments on both the stand and conveyor. Temperature is controlled by a solid state controller for consistent seal quality regardless of throughput.



**CALL FOR QUOTE**



### Features:

- All Stainless Steel Construction
- Seal Head & Conveyor Tilt up to 30 degree
- Solid State Temperature Control
- Standard Hot Stamp Code Imprinter
- Fully adjustable Stand & Conveyor

SPECIFICATIONS			
Model No.	Seal Speed Seal Width	Dimensions H x W x D	Ship Wt. (lbs.)
HBS880	0-320"/min 5/26" or 8mm	39" x 17" x 13" Conveyor: 43" x 8"	190

## Double Chamber Vacuum Sealer



This Double Chamber Vacuum Sealer allows you to cycle the sealing of multiple bags in one chamber while preparing additional bags on the other chamber. Sealing wires are wide (28") to allow for wider or multiple bags at a time in each chamber.

**CHECK OUT OUR WEBSITE FOR MORE PRODUCTS AND VIDEOS DEMOS**

## Vacuum Pack Sealer

This pneumatic tabletop vacuum sealer is made from high grade stainless steel and heavy-duty anodized aluminum and comes standard with a Venturi vacuum pump. Temperature control allows sealing of such challenging materials as Tyvek, Polyester, Nylon, Teflon, Vinyls, etc. A new color touch screen. The Retractable Nozzle Vacuum System uses two nozzles that extend out in front of the seal bar during loading and vacuum cycle and then retract during the sealing cycle. It comes in 4 sizes on the standard body--21", 26", 31", 36", and two sizes in the large body--51",61". This sealer is an unequalled product for both its quality and price. Optional stainless steel stand and shelf available.  
80 PSI / 5.7 CFM

### Features:

- 1/4" standard upper & lower heating elements
- New PLC/TS Control System
- Upper and lower heat bars
- Graphic screen control
- Built-in safety seal bar.
- Single-parted exhaust
- Venturi vacuum pump



**CMS**

**Charlie's Machine & Supply, Inc.**  
1067 S. Hover Street, E-181  
Longmont, CO 80503

Phone: 800-786-8455 or 303-443-9595  
www.charliesmachineandsupply.com  
email: info@charliesmachineandsupply.com

PRSR STD  
US POSTAGE  
PAID  
BOULDER, CO  
PERMIT NO. 94



**grating**



**slicing**



**crinkle**



**julienne**



**sticks**



**dicing**



**wedging**



**peeling**

## Web Online:



## Video Library:

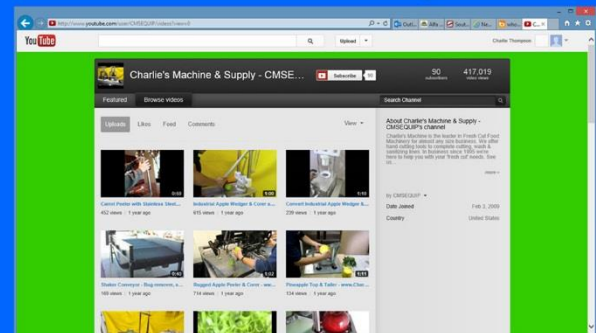

**www.charliesmachinesupply.com**

**FRESH CUT FOOD MACHINERY FOR ALL YOUR VEGETABLE AND FRUIT PROCESSING**